

# Directive Based GPU Programming

---

Orian Louant

CÉCI-CISM Training – November 30 2023

# The zoo of programming model for accelerators

## Central Processing Unit (CPU)

- latency-optimized
- general-purpose
- wide range of distinct tasks sequentially

## Graphics Processing Unit (GPU)

- throughput-optimized
- specialized
- highly parallel computing

## Low-Level Languages

- Cuda (NVIDIA)
- HIP (AMD)
- OpenCL (neutral)

## High-Level Frameworks

- Kokkos
- Raja
- Alpaka
- SyCL (DPC++)

## Directive Based Models

- OpenMP
- OpenACC

# Programming with directives

## OpenMP

- general-purpose parallel programming model
- the programmer explicitly spread the execution of loops, code regions, and tasks across team(s) of threads

```
#pragma omp construct [clauses]  
structured-block
```

```
!$omp construct [clauses]  
code-block  
!$omp end construct
```

## OpenACC

- oriented towards accelerators
- the programmer tells to the compiler which loops can be parallelized and let the compiler do the mapping to the target architecture

```
#pragma acc construct [clauses]  
structured-block
```

```
!$acc construct [clauses]  
code-block  
!$acc end construct
```

# OpenMP support for accelerator

- introduced with OpenMP 4.0, significantly extended in versions 4.5 and 5.0
- GPUs are the most common type of accelerator
- OpenMP is not limited to GPUs, you can use it to target any kind of accelerators (NEC SX-Aurora TSUBASA, FPGAs, ASICs, ...)
- makes it easier to target multiple heterogeneous architectures using the same code base

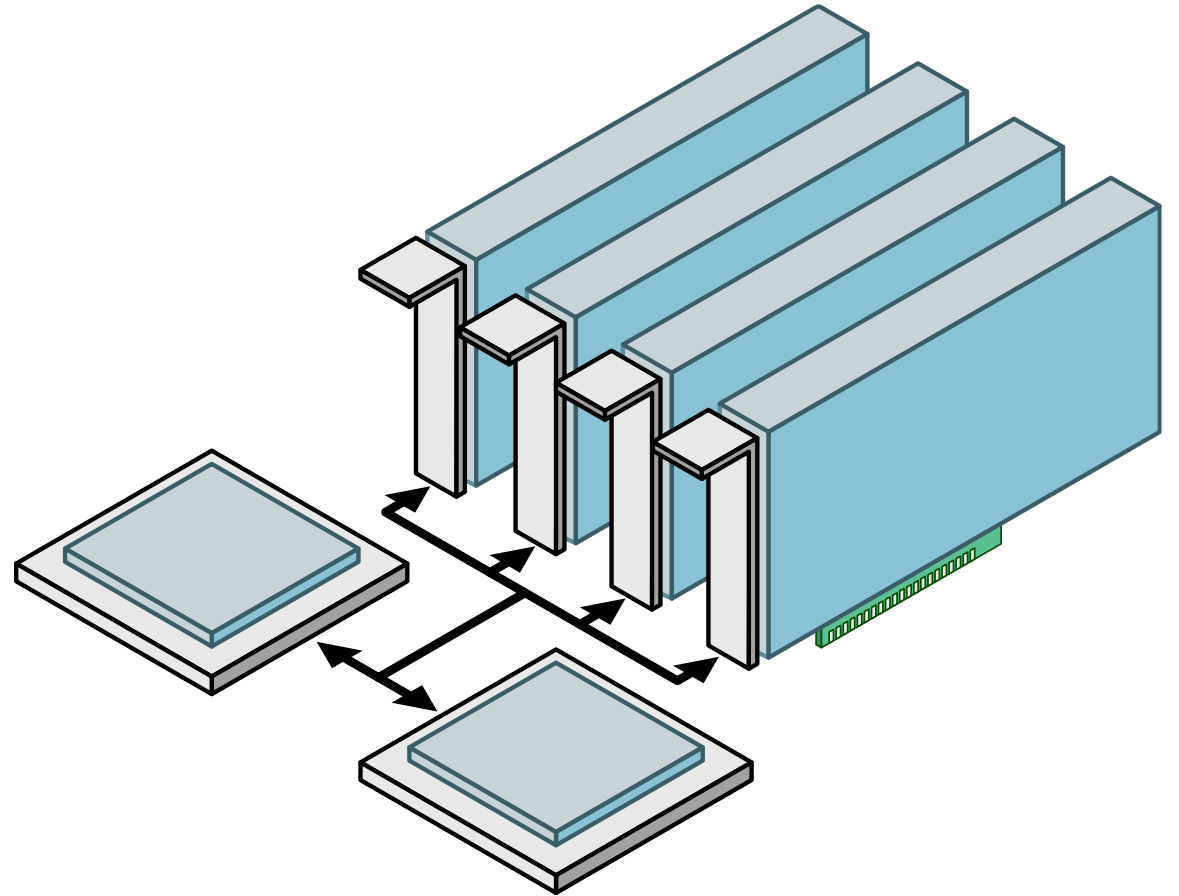

# OpenMP execution model

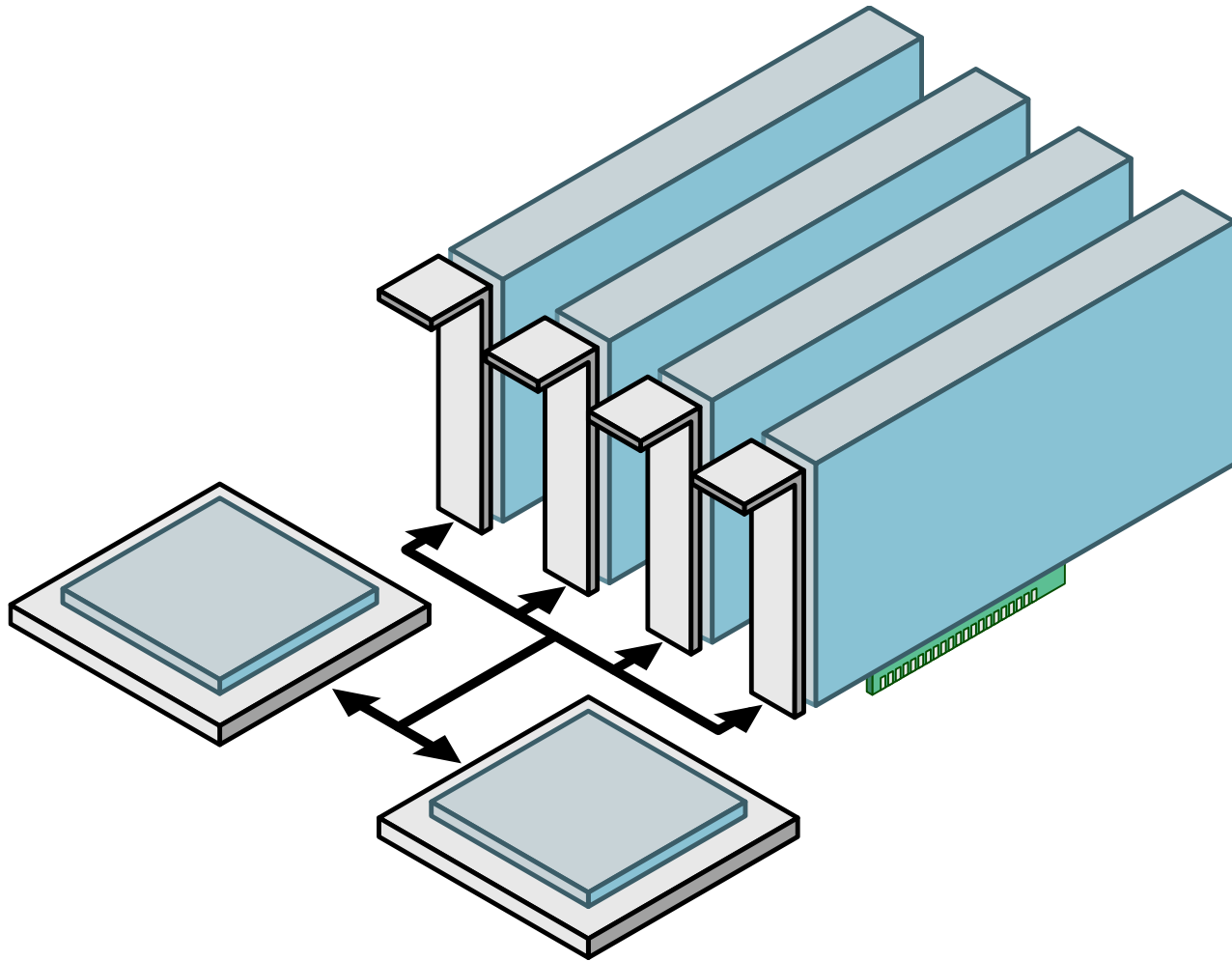

## Host

Where the execution starts. In almost all cases, this is the CPU

## Device

Multiple accelerator/coprocessor of the same type for offloading

# Host Multithreading

As a starting point to our journey to the world of GPU programming with directives, we will use a very simple kernel: `saxpy`

- `parallel`: create a team of threads that will start executing in parallel
- `for/do`: distribute the iteration of the loop within the team of threads

```
#pragma omp parallel for
for (int i = 0; i < n; ++i) {
    y[i] = a * x[i] + y[i];
}
```

```
!$omp parallel do
do i = 1,n
    y(i) = a * x(i) + y(i)
end do
!$omp end parallel do
```

# Offloading execution

The `target` directive instructs the compiler to generate a target task that will execute the enclosed block of code on a device

```
#pragma omp target  
structured-block
```

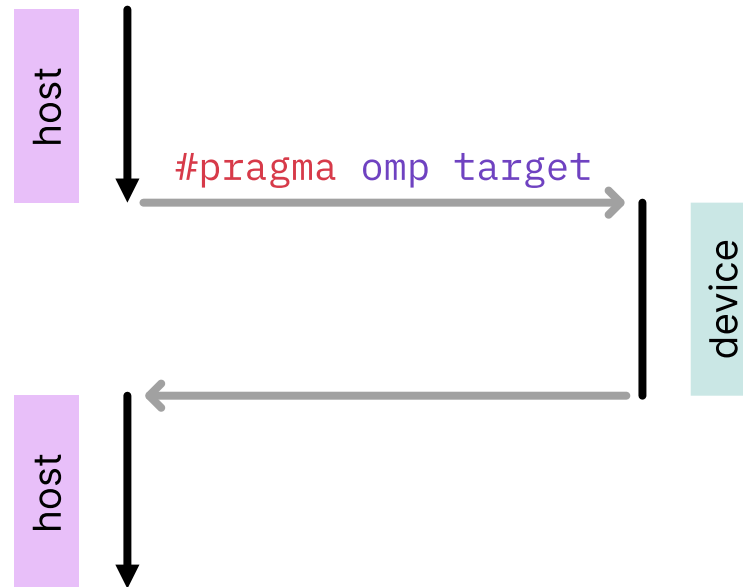

```
!$omp target  
code-block  
!$omp end target
```

```
#pragma omp target parallel for  
for (int i = 0; i < n; ++i) {  
    y[i] = a * x[i] + y[i];  
}
```

```
!$omp target parallel do  
do i = 1,n  
    y(i) = a * x(i) + y(i)  
end do  
!$omp end target parallel do
```

# Gather devices information

The `omp_get_num_devices` routine returns the number of target devices

Devices are assigned an ID from `0` to `ndev-1`. You can select the device to use for a `target` region by using the `device` clause

The `omp_is_initial_device` routine returns `true` if the current task is executing on the host device (CPU). It returns `false` if this is not the case

```
int on_host;
int ndev = omp_get_num_devices();

printf("Number of devices: %d\n", ndev);

for (int i = 0; i < ndev; i++) {
    #pragma omp target device(i) map(from:on_host)
    {
        on_host = omp_is_initial_device();
    }

    printf("Is initial device when on device %d: %d\n",
           i, on_host);
}

printf("Is initial device when on host: %d\n",
       omp_is_initial_device());
```



# Data in the device memory

Variable and arrays are present in the host (CPU) memory but not in the device memory

- in order to use a variable/array on the device, we need to have the data present in the device memory
- if we want to use data computed on the device, we need to update the data present in the host memory

```
#pragma omp target map(type:list)  
    structured-block
```

```
!$omp target map(type:list)  
    code-block
```

```
!$omp end target
```

---

Type	Description
<code>alloc</code>	allocate memory on the device
<code>to</code>	allocate memory on the device and copy the original values from the host to the device
<code>from</code>	allocate memory on the device and copy the values from the device to the host
<code>tofrom</code>	combination of <code>to</code> and <code>from</code> type

---

# Data in the device memory

- in C/C++, when moving array to and from the GPU, you need to specify the number of elements to be copied
- this is not required in Fortran

You can also copy part of an array:

```
#pragma omp target map(to:b[10:4])
```

```
!$omp target map(to:b[10:13])
```

**Note:** in C/C++ the syntax is [start:length] and [start:end] in Fortran

```
double a = 1234;
double *b = (double*)malloc(sizeof(double)*n);

#pragma omp target map(tofrom:a) \
                  map(to:b[0:n])
{
    // Code using a and b on the GPU
}
```

```
real(kind=real64) :: a
real(kind=real64), allocatable :: b(:)

allocate(b(n))

!$omp target map(tofrom:a) map(to:b)
    ! Code using a and b on the GPU
!$omp end target
```

# Moving data to and from the device

- `map(to:x)`: because we only read the array on the device
- `map(tofrom:y)`: because we read and modify the array on the device

Scalar variables that do not appear in a `map` clause default to `firstprivate`. As a consequence we don't need to map the variable `a` to the device

```
#pragma omp target parallel for map(to:x[0:n]) map(tofrom:y[0:n])
for (int i = 0; i < n; ++i) {
    y[i] = a * x[i] + y[i];
}
```

```
!$omp target parallel do map(to:x) map(tofrom:y)
do i = 1,n
    y(i) = a * x(i) + y(i)
end do
!$omp end target parallel do
```

# Compilers

## Clang (NVIDIA)

```
clang -fopenmp -fopenmp-targets=nvptx64-nvidia-cuda  
-Xopenmp-target=nvptx64-nvidia-cuda -march=<sm_XY> <source>
```

## Clang (AMD)

```
clang -fopenmp -fopenmp-target=amdgc-n-amd-amdhsa  
-Xopenmp-target=amdgc-n-amd-amdhsa -march=gfx<XXX> <source>
```

## NVIDIA HPC SDK (NVIDIA only)

```
nvc/nvfortran -mp=gpu -Minfo=mp -gpu=<ccXY> <source>
```

## GCC (NVIDIA, *ok performance with recent version*)

```
gcc/gfortran -fopenmp -foffload=nvptx-none <source>
```

# Using the Cray compiler (Lucia, LUMI)

Cray utilize target modules to define the target architecture for compilation. Once a `craype-accel-*` module is loaded, offloading is automatic if OpenMP is enabled (`-fopenmp`)

## Cray cc (NVIDIA)

```
module load PrgEnv-cray
module load nvhpc
module load craype-accel-nvidia80
cc -fopenmp <source>
```

## Cray cc (AMD)

```
module load PrgEnv-cray
module load rocm
module load craype-accel-amd-gfx90a
cc -fopenmp <source>
```

# A look to the hardware

A GPU is composed of multiple units each with their own registers, local memory and scheduler

- streaming multiprocessors (NVIDIA)
- compute units (AMD)

On a GPU, the work is scheduled in blocks that are executed on these units

- thread blocks (NVIDIA)
- workgroups (AMD)

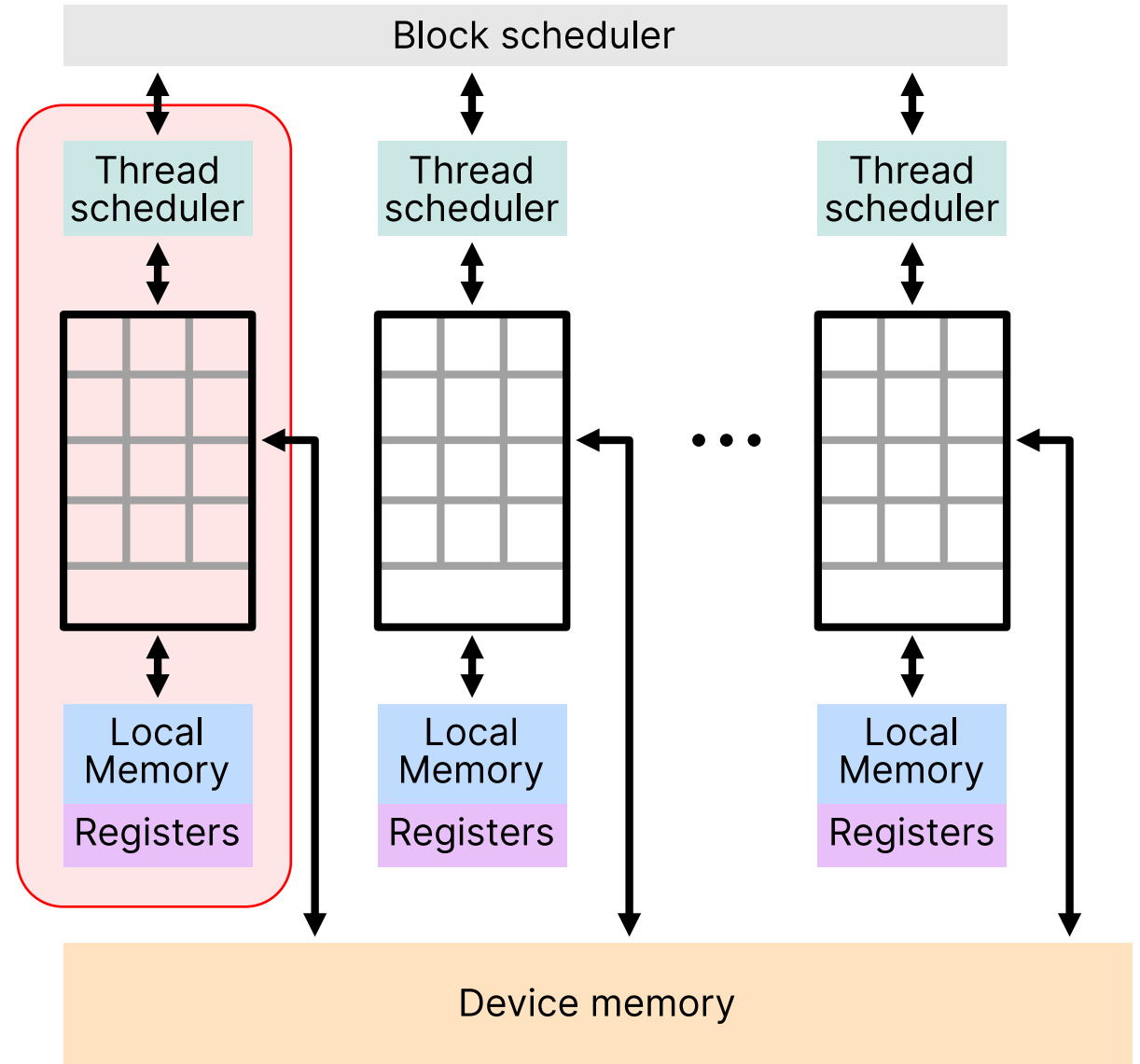

# A look to the hardware

The threads in a block are further divided in bundles that execute in lockstep: they run the same instructions, and follow the same control-flow path (SIMD fashion)

- 32 threads: warps (NVIDIA)
- 64 workitems: wavefront (AMD)

These bundles of threads execute on the vector units of the GPU

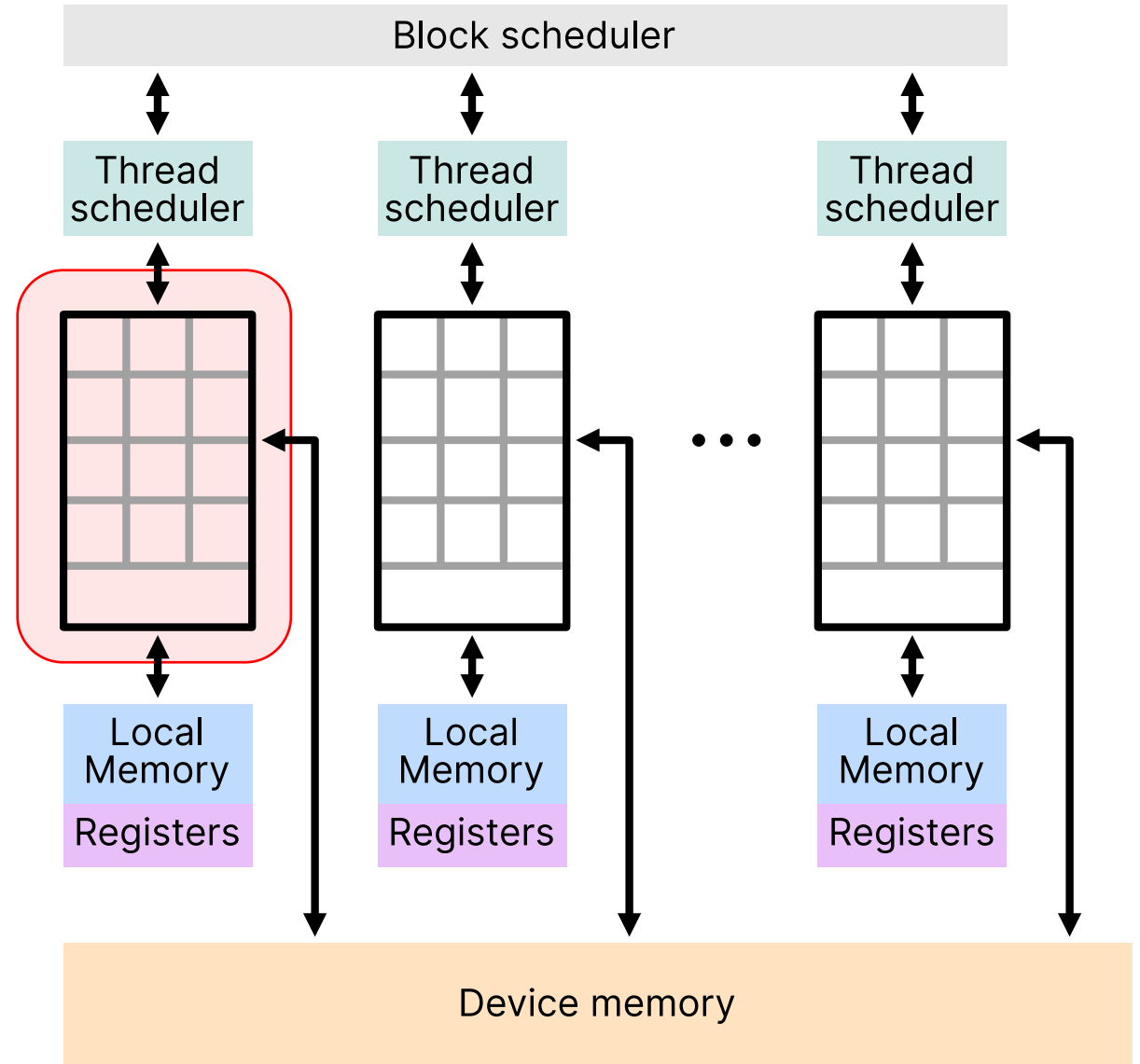

# A look to the hardware

```
#pragma omp target parallel for
for (int i = 0; i < n; ++i) {
    y[i] = a * x[i] + y[i];
}
```

We create only one team of threads that will use only one of the available units of our GPU

We need a way to create multiple teams so that we use the full potential of the hardware

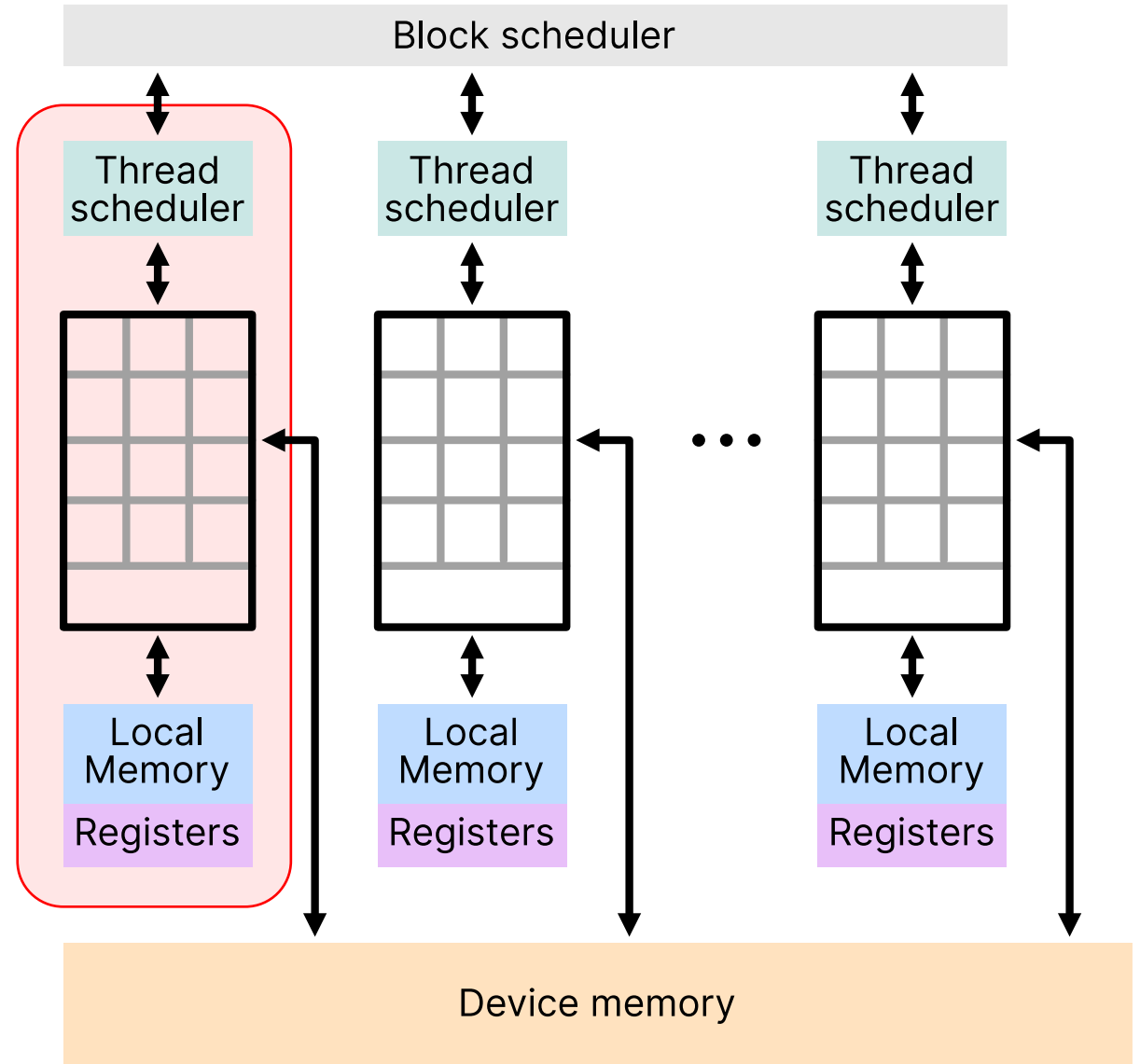



# The team construct: motivation

Let's consider some limitations of the hardware:

- no synchronization or memory fences possible between the streaming multiprocessors/compute units
- unlike CPUs where there is cache coherency between the cores, there is no such coherence between the streaming multiprocessors/compute units of a GPU

These limitations of the hardware have consequence if you consider “normal” OpenMP:

- creation of a parallel region, work-sharing tasks, ...
- barriers, critical regions, locks and atomics can be applied to a team of threads

In order to keep these characteristics on the devices an additional level was added, the `team` construct:

- multiple teams are spawned and each of these teams has a master threads
- the master thread can spawn a team of threads with a `parallel` construct
- threads in different teams cannot synchronize with each other but threads within a team can

# Creating teams and distribute work

When a `teams` construct is reached, a league of teams is created and the initial thread in each team executes the teams region

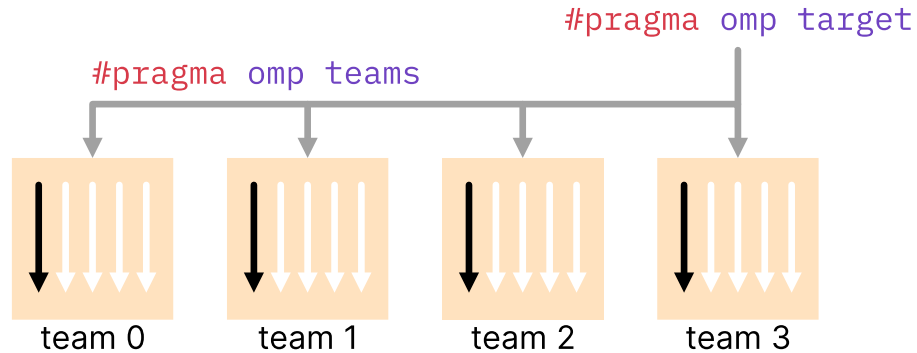

When a `distribute` construct is reached, the iterations of one or more loops will be distributed to the teams

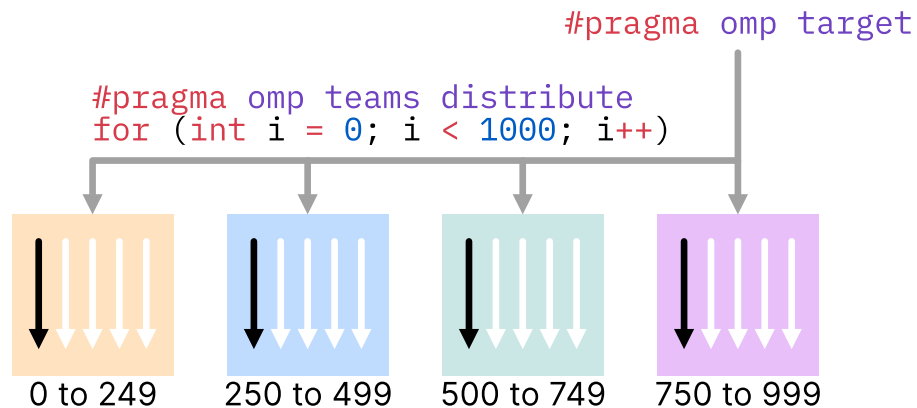

```
#pragma omp teams
    structured-block
```

```
!$omp teams
    structured-block
!$omp end teams
```

```
#pragma omp distribute
    for-loops
```

```
!$omp distribute
    do-loops
!$omp end distribute
```

# Get teams information

The number of teams can be controlled by the `num_teams` clause and the number of threads with the `thread_limit` clauses

```
#pragma omp teams num_teams(nteams) \                               !$omp  teams num_teams(nteams) &  
                thread_limit(nthreads)                               !$omp&      thread_limits(nthreads)
```

In addition, OpenMP provide runtime functions:

- `omp_get_num_teams()` returns the number of teams
- `omp_get_team_num()` returns the team number of the calling threads (0 to `nteams-1`)
- `omp_get_thread_limit()` returns the maximum number of threads

# Saxpy with teams distribute

- **target**: create a target task that will be executed on the GPU
- **team distribute**: create multiple teams of threads and distribute the loop iterations to these teams
- **parallel for/do**: distribute the iterations to the threads of the teams

```
#pragma omp target teams distribute parallel for \
                    map(to:x[0:n]) map(tofrom:y[0:n])
for (int i = 0; i < n; ++i) {
    y[i] = a * x[i] + y[i];
}
```

```
!$omp target teams distribute parallel do map(to:x) map(tofrom:y)
do i = 1,n
    y(i) = a * x(i) + y(i)
end do
!$omp end target teams distribute parallel do
```

# Jacobi 2D – host version

$$u_{i,j}^{N+1} = \frac{1}{4} (u_{i+1,j}^N + u_{i-1,j}^N + u_{i,j+1}^N + u_{i,j-1}^N)$$

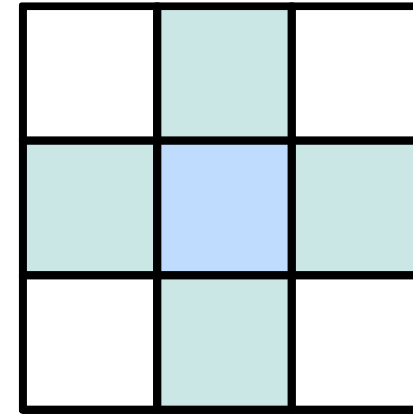

- point we want to compute
- additional points needed

```
while (err > tol && iter < iter_max) {
    err = 0.0;

    #pragma omp parallel for reduction(max:err)
    for (int j = 1; j < n-1; j++) {
        for (int i = 1; i < m-1; i++) {
            anew[j*m + i] = 0.25 * (uold[j*m + (i+1)] + uold[j*m + (i-1)]
                                   + uold[(j-1)*m + i] + uold[(j+1)*m + i]);

            err = fmax(err, fabs(anew[j*m + i] - uold[j*m + i]));
        }
    }

    // Swap values, uold <- anew
}
```

# Jacobi 2D – device version

$$u_{i,j}^{N+1} = \frac{1}{4} (u_{i+1,j}^N + u_{i-1,j}^N + u_{i,j+1}^N + u_{i,j-1}^N)$$

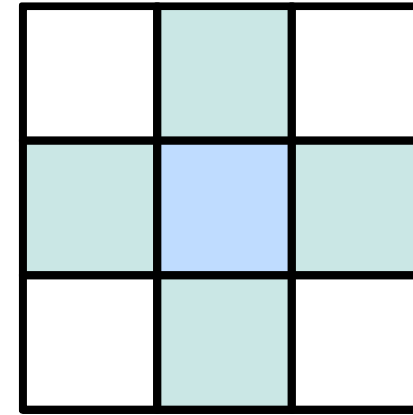

■ point we want to compute

■ additional points needed

```
while (err > tol && iter < iter_max) {
    err = 0.0;

    #pragma omp teams distribute parallel for reduction(max:err) \
        map(tofrom:uold[0:n*m]) map(from:unew[0:n*m])
    for (int j = 1; j < n-1; j++) {
        for (int i = 1; i < m-1; i++) {
            unew[j*m + i] = 0.25 * (uold[j*m + (i+1)] + uold[j*m + (i-1)]
                + uold[(j-1)*m + i] + uold[(j+1)*m + i]);

            err = fmax(err, fabs(unew[j*m + i] - uold[j*m + i]));
        }
    }

    // Swap values, uold <- unew
}
```

# Jacobi 2D

- if we run the multithreaded version of the Jacobi code on a CPU, we get a good speedup up to 8 threads and close to 21x speedup when we use the entire socket (AMD EPYC 7542, 32 cores)
- if we run on the GPU we see a small speedup on AMD compared to the serial execution but 10x slower compared to the 32 threads run
- on NVIDIA, the performance is even worse, with a 0.89x speedup compared to the serial run

Number of threads	Time (s)	Speedup
1	28.433	1.00
4	7.140	3.98
8	3.718	7.64
16	2.117	13.43
32	1.376	20.66
<b>AMD MI250x</b> <sup>(1)</sup>	11.842	2.41
<b>NVIDIA A100</b> <sup>(2)</sup>	31.694	0.89

(1) Cray compiler, CPE 22.08, ROCm 5.1

(2) Clang 16.0.6, CUDA 11.7

# Jacobi 2D

In order to understand to poor performance of the GPU version, we will do a quick profiling

We can use `nsys` (NVIDIA) or the `LIBOMPTARGET_KERNEL_TRACE` environment variable (AMD).

```
__tgt_rtl_data_alloc:      64us
__tgt_rtl_data_alloc:      53us
__tgt_rtl_data_submit_async: 33674us
__tgt_rtl_data_alloc:       3us
__tgt_rtl_data_submit_async: 135us
__tgt_rtl_run_target_team_region: 4879us
__tgt_rtl_data_retrieve_async: 93us
__tgt_rtl_data_retrieve_async: 32358us
__tgt_rtl_data_retrieve_async: 32632us
__tgt_rtl_synchronize:      0us
__tgt_rtl_data_delete:       4us
__tgt_rtl_data_delete:      26us
__tgt_rtl_data_delete:      17us
```

Number of threads	Time (s)	Speedup
1	28.433	1.00
4	7.140	3.98
8	3.718	7.64
16	2.117	13.43
32	1.376	20.66
<b>AMD MI250x <sup>(1)</sup></b>	<b>11.842</b>	<b>2.41</b>
<b>NVIDIA A100 <sup>(2)</sup></b>	<b>31.694</b>	<b>0.89</b>

(1) Cray compiler, CPE 22.08, ROCm 5.1

(2) Clang 16.0.6, CUDA 11.7



# Efficient movement of data

From the result of a quick profiling of the Jacobi code on the GPU, we see that

- moving data to and from the device at every iteration is inefficient
- better solution is to copy the data to the device and keep it on the device between iterations

For that we can use a structured data region that Map variables to a device data environment for the extent of the region

```
#pragma omp target data map(type:list)  
    structured-block
```

```
!$omp target data map(type:list)  
    structured-block  
!$omp end target data
```

# Jacobi 2D with a structured data region

In order to improve the movement of data, we create a data region that covers the entire while loop so that we don't copy data to and from the GPU between iterations

```
#pragma omp target data map(tofrom:uold[0:n*m]) map(alloc:unew[0:n*m])
while (err > tol && iter < iter_max) {
    err = 0.0;

    #pragma omp target teams distribute parallel for reduction(max:err)
    for (int j = 1; j < n-1; j++) {
        for (int i = 1; i < m-1; i++) {
            unew[j*m + i] = 0.25 * (uold[j*m + (i+1)] + uold[j*m + (i-1)]
                                   + uold[(j-1)*m + i] + uold[(j+1)*m + i]);

            err = fmax(err, fabs(unew[j*m + i] - uold[j*m + i]));
        }
    }

    // swap values, uold <- unew
} // end of the data region
```

# Unstructured data

- for data regions that span multiple lexical scopes (functions or files) you can use an unstructured data region
- data movement or allocation to the device is done with the `enter data` directive
- data movement or deallocation from the device is done with the `exit data` directive
- update of data in the middle of an unstructured data region, you can use the `target update` directive (from the host)

```
#pragma omp target enter data map(type:list)
```

```
#pragma omp target update to|from(list)
```

```
#pragma omp target exit data map(type:list)
```

```
!$omp target enter data map(type:list)
```

```
!$omp target update to|from(list)
```

```
!$omp end target exit data map(type:list)
```

# The update directive

- you can update data in the middle of a data region, you can use the `target update` directive with clauses
  - `from`: data on the host is updated with data from the device
  - `to`: data on the device is updated with the data from the host
- this directive can be used in the middle of a structured or unstructured data region

```
#pragma omp target data map(tofrom:a[0:n])  
{  
    // do something with a on the device  
    #pragma omp target update from(a[0:n])  
    // do something with a on the host  
    #pragma omp target update to(a[0:n])  
    // do something with a on the device  
}
```

```
!$omp target data map(tofrom:a)  
    ! do something with a on the device  
    !$omp target update from(a)  
    ! do something with a on the host  
    !$omp target update to(a)  
    ! do something with a on the device  
!$omp end target data
```

# Jacobi 2D with unstructured data directives

```
#pragma omp target enter data map(to:uold[0:n*m]) map(alloc:unew[0:n*m])

while (err > tol && iter < iter_max) {
    err = 0.0;

    #pragma omp target teams distribute parallel for reduction(max:err)
    for (int j = 1; j < n-1; j++) {
        for (int i = 1; i < m-1; i++) {
            unew[j*m + i] = 0.25 * (uold[j*m + (i+1)] + uold[j*m + (i-1)]
                                   + uold[(j-1)*m + i] + uold[(j+1)*m + i]);

            err = fmax(err, fabs(unew[j*m + i] - uold[j*m + i]));
        }
    }

    // swap values, uold <- unew
}

#pragma omp target exit data map(from:uold[0:n*m]) map(delete:unew[0:n*m])
```

# Jacobi 2D with a data region

Now that we have removed unnecessary data movement we see

- a huge improvement compared to the first version without data movement optimization
- still, we only achieved a ~9x speedup on the MI250x GPU compared to the serial CPU version
- Significant speed up for the A100 (28x)

Number of threads	Time (s)	Speedup
1	28.433	1.00
4	7.140	3.98
8	3.718	7.64
16	2.117	13.43
32	1.376	20.66
<hr/>		
<b>AMD MI250x</b> (1)	11.842	2.41
(2)	3.265	8.71
<hr/>		
<b>NVIDIA A100</b> (1)	31.694	0.89
(2)	1.010	28.15

(1) with no data movement optimization

(2) with data movement optimization

# Enabling more parallelism

By only parallelizing the outer loop, we do not fully exploit the parallelism of the hardware

- distribute the iterations of the outer loop to the teams
- distribute the iterations of the inner loop to the threads

```
#pragma omp target data map(tofrom:uold[0:n*m]) map(alloc:unew[0:n*m])
while (err > tol && iter < iter_max) {
    err = 0.0;

    #pragma omp target teams distribute reduction(max:err)
    for (int j = 1; j < n-1; j++) {
        #pragma omp parallel for reduction(max:err)
        for (int i = 1; i < m-1; i++) {
            unew[j*m + i] = 0.25 * (uold[j*m + (i+1)] + uold[j*m + (i-1)]
                                   + uold[(j-1)*m + i] + uold[(j+1)*m + i]);

            err = fmax(err, fabs(unew[j*m + i] - uold[j*m + i]));
        }
    }

    // swap values, uold <- unew
} // end of the data region
```

# Enabling more parallelism

By distributing both loops, the first across teams and the second across threads we increase parallelism.

- for CPUs it's not recommended to use more threads than the available cores/hardware threads on the system
- for GPUs, in order to hide memory latency, you need to use more threads than what the hardware is capable of executing at the same time
- Increasing the parallelism leads to 2x improvement on the A100 and more than 6x for the MI250x compared to the version where we only parallelize the outer loop

Number of threads	Time (s)	Speedup
1	28.433	1.00
4	7.140	3.98
8	3.718	7.64
16	2.117	13.43
32	1.376	20.66
<b>AMD MI250x</b> (1)	3.265	8.71
(2)	0.526	54.05
<b>NVIDIA A100</b> (1)	1.010	28.15
(2)	0.581	48.94

(1) parallelization of the outer loop

(2) outer loop across teams and inner loop across threads



# Enabling more parallelism with loop collapsing

Another way to increase the parallelism is to collapse the loop nest. For a `for` or `distribute` construct, if a collapse clause is present and more the one loop is associated with the construct, then the iteration of all associated loops are collapsed into one larger iteration space

```
#pragma omp target data map(tofrom:uold[0:n*m]) map(alloc:unew[0:n*m])
while (err > tol && iter < iter_max) {
    err = 0.0;

    #pragma omp target teams distribute parallel for collapse(2) reduction(max:err)
    for (int j = 1; j < n-1; j++) {
        for (int i = 1; i < m-1; i++) {
            unew[j*m + i] = 0.25 * (uold[j*m + (i+1)] + uold[j*m + (i-1)]
                                   + uold[(j-1)*m + i] + uold[(j+1)*m + i]);

            err = fmax(err, fabs(unew[j*m + i] - uold[j*m + i]));
        }
    }

    // swap values, uold <- unew
} // end of the data region
```

# Loop collapsing

Collapsing the loops is an other way to increase parallelism on the GPU

- No change is the observed speedup for the MI250x as well as for the A100

Number of threads	Time (s)	Speedup
1	28.433	1.00
4	7.140	3.98
8	3.718	7.64
16	2.117	13.43
32	1.376	20.66
<hr/>		
<b>AMD MI250x</b> (1)	0.526	54.05
(2)	0.522	54.46
<hr/>		
<b>NVIDIA A100</b> (1)	0.566	48.94
(2)	0.581	48.93

(1) outer loop across teams and inner loop across threads

(2) collapsing the two loops

# Structure mapping

Scalar member of a structure will be copied at the same time as the base structure

However, OpenMP target offload do not have support for deep copy:

- we have to be careful when using structure with non-scalar members (arrays)
- non-scalar members need to be mapped explicitly by the developer

Structure pointers are arrays of size 1 and need to be mapped explicitly by the developer

```
typedef struct saxpy_data {
    int size;
    float *x, *y;
    float a;
} saxpy_data_t;

void saxpy(saxpy_data_t *data) {
    #pragma omp target teams distribute parallel for \
        map( to:data[0:1]) \
        map( to:data->x[0:data->size]) \
        map(tofrom:data->y[0:data->size])
    for(int i = 0; i < data->size; i++) {
        data->y[i] = data->a * data->x[i] + data->y[i];
    }
}
```

# User-defined mapper

When a structure is heavily used in the application, it can be tiresome to explicitly map it every time we want to use it to the device

OpenMP offer user-defined mapper to tackle this problem: the developer can define how a structure should be mapped to the device

The `declare mapper` directive declares a user-defined mapper for a given type and may define a `mapper-identifier` that can be used in a map clause.

```
#pragma omp declare mapper([mapper-identifier:]type var) \  
                           [clause[ [,] clause] ... ]
```

where `clause` is `map([map-type: ] list)` which is the same syntax as for the mapping clause of a data region.

# User-defined mapper

Using the `declare mapper` directive, we can how a structure should be copied to the device:

- we specify that the mapper applies to the `saxpy_data_t` type and defines an identifier for the structure (`data`)
- we map the base structure with a `to` modifier which means that the `size` and `a` members will be copied to the device when entering the data region but not copied back the host when we exit the region. We also allocate and attach the `x` and `y` arrays
- as we use a pointer to the `saxpy_data_t` structure, the mapping of the structure to the device is done with `map(data[0:1])`

```
typedef struct saxpy_data {
    int size;
    float *x, *y;
    float a;
} saxpy_data_t;

#pragma omp declare mapper(saxpy_data_t data) \
    map(to:data) \
    map(to:data.x[0:data.size]) \
    map( data.y[0:data.size])

void saxpy(saxpy_data_t *data) {
    #pragma omp target teams distribute parallel for \
        map(data[0:1])
    for(int i = 0; i < data->size; i++) {
        data->y[i] = data->a * data->x[i] + data->y[i];
    }
}
```

# Prescriptive vs. Descriptive model

## **OpenMP is descriptive**

The OpenMP directives instruct the compiler to generate parallel code in a specific way, leaving little to the discretion of the compiler

## **OpenACC is prescriptive**

OpenACC directives tell the compiler that a loop can be parallelized. The compiler is free to run them in parallel any way it chooses and choose very different mappings depending on the underlying hardware

# The kernels construct

The `kernels` construct defines a region that is to be compiled into a sequence of kernels for execution on the device

- the compiler will analyse the code and splits it in a sequence of device kernels
- typically each loop nest will become a kernel

```
#pragma acc kernels  
    structured-block
```

```
!$acc kernels  
    code-block
```

```
!$acc end kernels
```

```
#pragma acc kernels  
{  
    // A first kernel generated here  
    for (int i = 0; i < n; i++) {  
        x[i] = 1.0;  
        y[i] = 2.0;  
    }  
    // A second kernel generated here  
    for (int i = 0; i < n; i++) {  
        y[i] = i*x[i] + y[i];  
        sum += y[i];  
    }  
}
```

```
!$acc kernels  
    ! A first kernel generated here  
    do i = 0, n  
        x(i) = 1.0  
        y(i) = 2.0  
    end do  
    ! A second kernel generated here  
    do i = 0, n  
        y(i) = i*x(i) + y(i)  
        sum = sum + y[i]  
    end do  
!$acc end kernels
```

# The parallel construct

The `parallel` construct starts parallel execution on the device

```
#pragma acc parallel  
    structured-block
```

```
!$acc parallel  
    code-block  
!$acc end parallel
```

The `loop` construct identifies a loop eligible for parallelization

```
#pragma acc loop  
    for-loop
```

```
!$acc loop  
    do-loop
```

```
#pragma acc parallel  
{  
    #pragma acc loop  
    for (int i = 0; i < n; i++) {  
        x[i] = 1.0;  
        y[i] = 2.0;  
    }  
}
```

```
#pragma acc loop  
for (int i = 0; i < n; i++) {  
    y[i] = i*x[i] + y[i];  
    sum += y[i];  
}  
}
```

```
!$acc parallel  
!$acc loop  
do i = 0, n  
    x(i) = 1.0  
    y(i) = 2.0  
end do
```

```
!$acc loop  
do i = 0, n  
    y(i) = i*x(i) + y(i)  
    sum = sum + y[i]  
end do  
!$acc end parallel
```



# Data movement clauses

OpenACC data movement directives are very similar to the OpenMP directives: like with the `target` construct you can use data clauses with the `kernels` or parallel `construct`

```
#pragma acc kernels clause(list)           !$acc kernels clause(list)
```

```
#pragma acc parallel clause(list)         !$acc parallel clause(list)
```

---

Clause	Description
<code>create</code>	allocate memory on the device
<code>delete</code>	deallocate memory on the device
<code>copyin</code>	allocate memory on the device and copy the original values from the host to the device
<code>copyout</code>	allocate memory on the device and copy the values from the device to the host
<code>copy</code>	combination of <code>copyin</code> and <code>copyout</code>

---

# Data region

Structured data region data region are created using the `data` directive

```
#pragma acc data clause(list)          !$acc data clause(list)
    structured-block                    code-block
                                       !$acc end data
```

For unstructured data regions:

- data movement or allocation to the device is done with the `enter data` directive
- data movement or deallocation from the device are done with the `exit data` directive

```
#pragma acc enter data clause(list)    !$acc enter data clause(list)
```

```
#pragma acc exit data clause(list)     !$acc exit data clause(list)
```

# The update directive

- you can update data in the middle of an data region, you can use the `update` directive clauses:
  - `host`: data on the host is updated with data from the device (you can also use `self`)
  - `device`: data on the device is updated with the data from the host
- this directive can be used in the middle of a structured or unstructured data region

```
#pragma acc data map(tofrom:a[0:n])
{
    // do something with a on the device
    #pragma acc update host(a[0:n])
    // do something with a on the host
    #pragma acc update device(a[0:n])
    // do something with a on the device
}
```

```
!$acc data map(tofrom:a)
    ! do something with a on the device
    !$acc update host(a)
    ! do something with a on the host
    !$acc update device(a)
    ! do something with a on the device
!$acc end data
```

# OpenACC saxpy

We have two options to implement our saxpy example with OpenACC

- using a `kernel` directive and let the compiler analyze our code and generate a kernel that will execute on the GPU
- using a combined `parallel loop` directive to explicitly indicate to the compiler where the source of parallelism is

```
#pragma acc kernels copyin(x[0:n]) copy(y[0:n])
for (int i = 0; i < n; ++i) {
    y[i] = a * x[i] + y[i];
}
```

```
!$acc kernels copyin(x) copy(y)
do i = 1,n
    y(i) = a * x(i) + y(i)
end do
!$acc end kernels
```

```
#pragma acc parallel loop copyin(x[0:n])
copy(y[0:n])
for (int i = 0; i < n; ++i) {
    y[i] = a * x[i] + y[i];
}
```

```
!$acc parallel loop copyin(x) copy(y)
do i = 1,n
    y(i) = a * x(i) + y(i)
end do
!$acc end parallel loop
```

# Compilers

OpenACC is not as widely supported by compilers as OpenMP:

- the best implementation is the NVIDIA compiler
- it is possible to use GCC to target both NVIDIA and AMD GPUs
- some commercial compilers, like the HPE Cray one include support for OpenACC

## **NVIDIA HPC SDK (NVIDIA only)**

```
nvc/nvfortran -acc -Minfo=acc -gpu=<ccXY> <source>
```

## **GCC (NVIDIA, *ok performance with recent version*)**

```
gcc/gfortran -fopenacc -foffload=nvptx-none <source>
```

# OpenACC Jacobi

- the `parallel loop` construct create a region to be executed on the device and indicate that the outer loop is parallelizable
- the `loop` directive on the inner loop indicates to the compiler that it is parallelizable as well

```
#pragma acc data copy(uold[0:n*m]) create(unew[0:n*m])
while (err > tol && iter < iter_max) {
    err = 0.0;

    #pragma acc parallel loop reduction(max:err)
    for (int j = 1; j < n-1; j++) {
        #pragma acc loop reduction(max:err)
        for (int i = 1; i < m-1; i++) {
            unew[j*m + i] = 0.25 * (uold[j*m + (i+1)] + uold[j*m + (i-1)]
                                   + uold[(j-1)*m + i] + uold[(j+1)*m + i]);

            err = fmax(err, fabs(unew[j*m + i] - uold[j*m + i]));
        }
    }

    // swap values, uold <- unew
} // end of the data region
```

# OpenACC Jacobi

Similarly to to what we did with the OpenMP version, we can also collapse the nested loop nest with the `collapse` clause.

```
#pragma acc data copy(uold[0:n*m]) create(unew[0:n*m])
while (err > tol && iter < iter_max) {
    err = 0.0;

    #pragma acc parallel loop collapse(2) reduction(max:err)
    for (int j = 1; j < n-1; j++) {
        for (int i = 1; i < m-1; i++) {
            unew[j*m + i] = 0.25 * (uold[j*m      + (i+1)] + uold[j*m      + (i-1)]
                                   + uold[(j-1)*m +      i] + uold[(j+1)*m +      i]);

            err = fmax(err, fabs(unew[j*m + i] - uold[j*m + i]));
        }
    }

    // swap values, uold <- unew
} // end of the data region
```

# Coalescent memory access

## Coalescent memory access

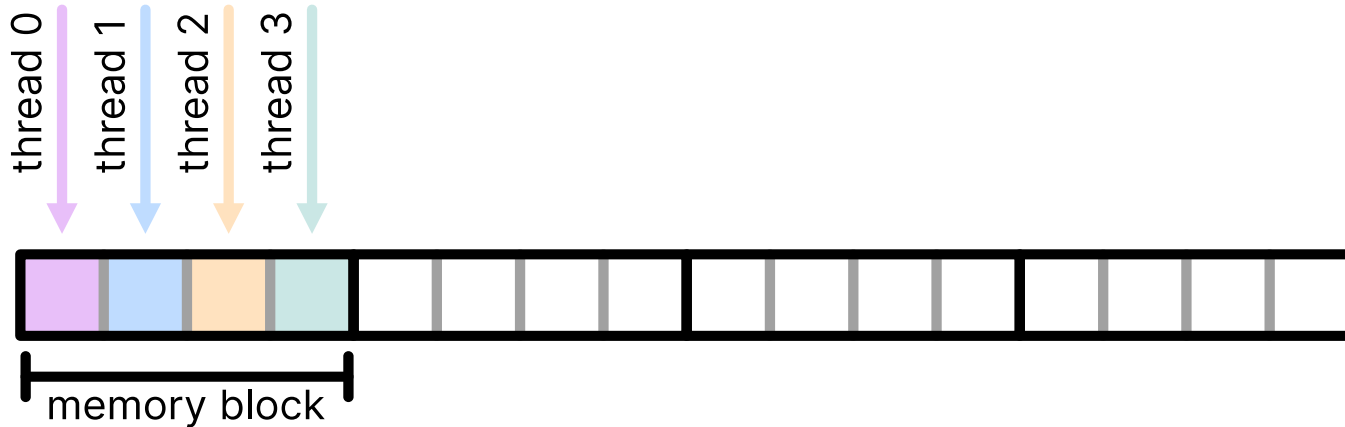

## Uncoalescent memory access

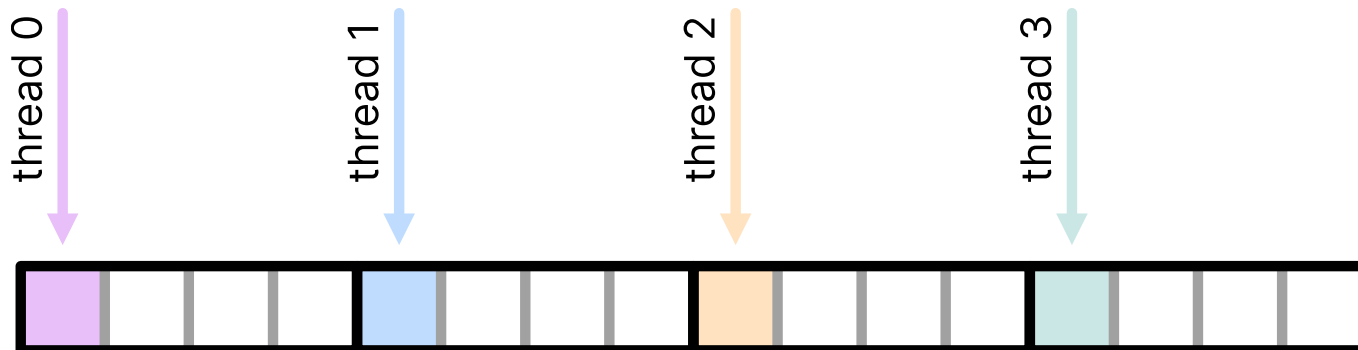

Coalesced memory access refers to combining multiple memory accesses into a single transaction

- when a thread access the GPU global memory it always access a the memory in chunks
- if other threads access the same chunk at the same time then the chunk can be reused
- the most efficient access is when threads read or write contiguous memory locations
- strided memory access is not optimal as more memory transactions are required to read/write the same amount of data



# AoS and SoA

**Array of Structures:** cache friendly

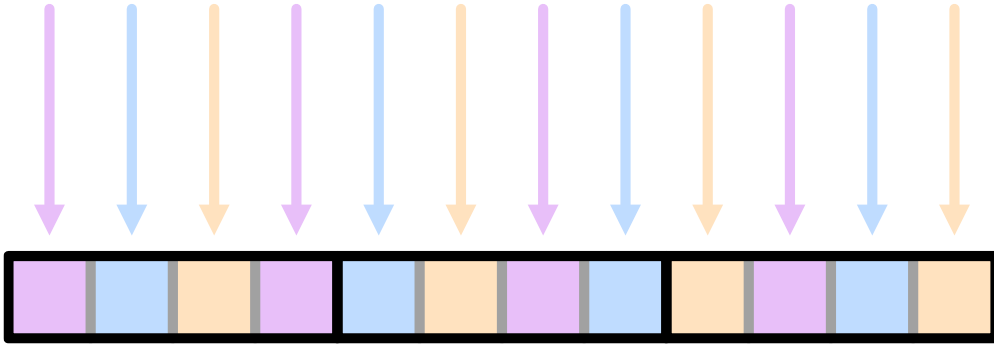

**Structure of arrays:** coalescent access

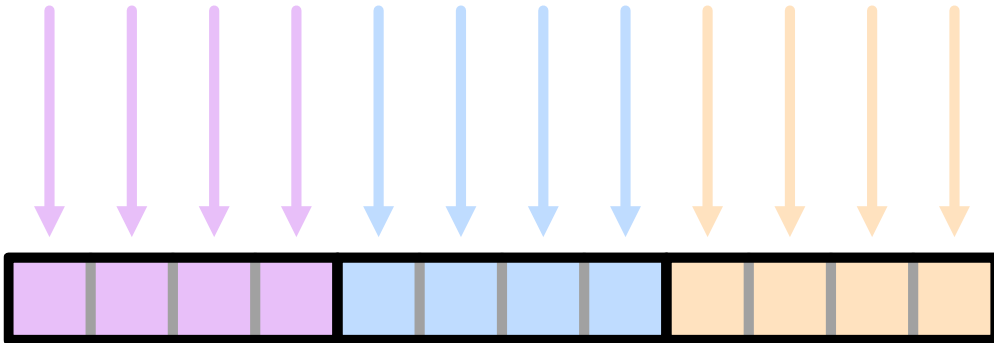

```
struct point {  
    float x;  
    float y;  
    float z;  
};  
struct point points[n];
```

```
struct points_list {  
    float x[n];  
    float y[n];  
    float z[n];  
};  
struct points_list points;
```

# Wrapping-up

OpenMP and OpenACC allows you to target GPUs with a few directives added to your code. While adding these directives is relatively easy:

## **Transferring data between the host and the device is an expensive process**

- data transfer may be the main bottleneck when running on a accelerator is not handled carefully
- only transfer data required on the device
- try to keep the data on the device as long as possible
- use structured data region (`target data`) or unstructured data region (`target enter/exit data`)

## **You need sufficient parallelism in order to achieve good performance**

- need to expose more parallelism than for CPUs
- can be achieved by distributing loops across teams and across threads
- for tightly nested loop collapsing is also an option



**EuroHPC**  
Joint Undertaking

This training was partially developed in the framework of the EuroCC project that has received funding from the European High-Performance Computing Joint Undertaking (JU) under grant agreement No 951732. The JU receives support from the European Union's Horizon 2020 research and innovation programme and Germany, Bulgaria, Austria, Croatia, Cyprus, Czech Republic, Denmark, Estonia, Finland, Greece, Hungary, Ireland, Italy, Lithuania, Latvia, Poland, Portugal, Romania, Slovenia, Spain, Sweden, United Kingdom, France, Netherlands, Belgium, Luxembourg, Slovakia, Norway, Switzerland, Turkey, Republic of North Macedonia, Iceland, Montenegro.